

# BOLTLESS 5 TIER SHELVING UNIT

## Before you start

- Check pack to ensure you have all the parts listed in the contents.
- When ready to start ensure that you have plenty of space for assembly.
- Take care assembling this shelf unit as there may be some sharp edges or corners.
- The maximum weight loading is 60kg per shelf. If the unit is going to be loaded to its maximum capacity. It must be firmly fastened to the wall using the wall retainers supplied and suitable screws and plugs (not supplied).

## CONTENTS

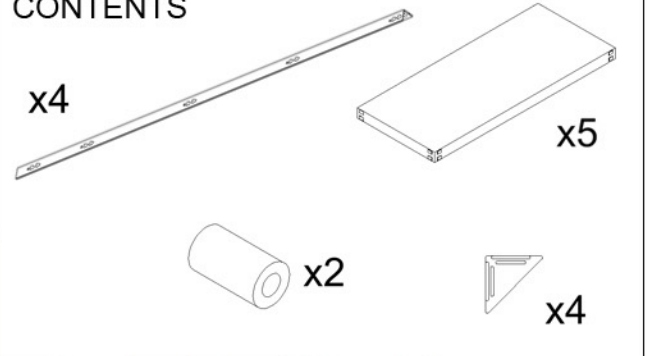

## Assembly Instructions

- Diagram 1 - Take one upright and one shelf. Hold the upright vertically and place the louvres of the shelf over the fixing tabs (see diagram A). Tap the shelf down to fully locate the tabs.
- Diagram 2 - Repeat the process until you have all four uprights located. If the connections are tight you may wish to use a rubber mallet or a hammer taking care to protect the shelf with a flat piece of wood.
- Diagram 3 - Locate the remaining shelves one at a time making sure all of the tabs are correctly located in the louvres.

